

# HOMESTYLE™ Aspen

---

Oxygen Concentrator

































**User Manual (EN)**  
Model: SCE1000-NANB

**RX ONLY**  
U.S. Federal Regulation  
Restricts this Device  
to Sale by order of Physician

Model colors may vary.

## User Controls & System Status Indicators

Symbol	Description of Symbol
	Manufacturer
	Date of Manufacture
	Catalog Number
	Keep Dry
	Consult Instructions for Use
	Unique Device Identifier
	Fragile, handle with care
	Recycle
	Storage Humidity Range
<b>IP21</b>	<b>Dust Class:</b> Prevent particles with diameter of 12.5 mm from entering. <b>Waterproof rating:</b> Prevent water from falling vertically.
	Refer to instruction manual/booklet
	No open flame: Fire, open ignition source and smoking prohibited.
	Class II Equipment, Double Insulated
	Type BF Applied Part
	Use no oil or grease
	ON (Power Switch On)
	Do Not Sit

<b>RX ONLY</b>	<b>Prescription Use Only:</b> Federal law restricts this device to sale by or on the order of a physician.
	<b>Authorized Representative in the European Community</b>
	Caution
	Serial Number
	Temperature Limit
	Medical Device
	CE Mark
	This way up
	Stacking limit by number
	Atmospheric pressure limitation
	<b>Importer:</b> To indicate the entity importing the medical device
	Country of Manufacture
	No Smoking
	“Warning” symbol
	<i>Waste Electrical and Electronic Equipment. Do not dispose of in unsorted municipal waste.</i>
	Do not disassemble
<b>0</b>	<b>OFF (Power Switch Off)</b>

This Page Intentionally Left Blank

## Introduction and Product Contents

This user manual provides information for users of the CAIRE HOMESTYLE™ Aspen oxygen concentrator. This manual describes the warnings and cautions, operating instructions, basic functions, technical specifications, basic troubleshooting, return repair instructions and other content, so that you will be familiar with the products and operation of the device.

To ensure the effective use of this device, please read the instructions carefully in this manual. Before operating the device, please ensure that you have read and understood the basic operating instructions. Please pay special attention to “SAFETY INSTRUCTIONS.”

### CHECK PACKAGE AND PACKING LIST

When you receive the product, please open the package carefully. This product is equipped with upper and lower foam protection covers. If the protective cover is damaged, please check immediately whether the product is also damaged. Then, check if there are any missing parts or accessories in the inspection of the packing list of the products.

Packing List			
No.	Description	Quantity	Unit
1	Oxygen Concentrator	1	Piece
4	Air intake filter	1	Piece
5	User Manual	1	Piece

Please note that some illustrations in this manual are not meant to be realistic depictions of the actual device or accessories. Please refer to the actual device.

The humidifier bottle, nasal cannula, filters and other components mentioned in this manual should be selected in accordance with the requirements of product specifications.

## Intended Use and Indications

### Intended Use

The HOMESTYLE Aspen oxygen concentrator is intended for the administration of supplementation oxygen. The device may be used in the home or healthcare institution environment.

The device is not intended for life support, nor does it provide any patient monitoring capabilities.

### INDICATIONS FOR USE AND CLINICAL BENEFIT

The HOMESTYLE Aspen oxygen concentrator is used on a prescriptive basis by patients requiring supplemental oxygen to increase blood oxygen saturation.

Patients should use this oxygen concentrator under the guidance of a prescriber. Patients should consult a healthcare professional before using an oxygen concentrator. Oxygen therapy may be harmful under certain conditions.

### CONTRAINDICATIONS

This oxygen concentrator is not intended as life support and cannot be used to maintain life. Patients should follow the guidance of the prescriber for flow rate level(s) and oxygen utilization time when using the oxygen concentrator.

- Patients with severe lung disease should consult their prescriber for the preferred oxygen therapy method.
- Patients who show discomfort or abnormal reactions when inhaling oxygen should stop using this oxygen concentrator immediately and contact the equipment supplier or prescriber.
- Patients with oxygen toxicity or oxygen allergy (oxygen anaphylaxis or oxygen hypersensitivity) should not use this device.

## Safety Instructions



### WARNING:

Failure to use the oxygen concentrator in accordance with the warnings, cautions, and instructions below may cause serious injury or death.

DO NOT use the oxygen concentrator when bathing to avoid the risk of burns, electric shock, fire, or other injury. If needed, please consult with your doctor. The manufacturer advises keeping the oxygen concentrator outside the bathroom 8 feet away.

DO NOT use an oxygen cannula more than 11 meters or 36 feet in length.

DO NOT use or store the oxygen concentrator in a place where it is easy to drop into water or other liquid around the oxygen concentrator.

DO NOT use the oxygen concentrator within 5 feet of hot, sparking objects or sources of flames. Oxygen causes rapid burning.

DO NOT smoke while your oxygen concentrator is operating, or when you are near a person utilizing oxygen therapy.

DO NOT use the oxygen concentrator if it appears broken or has a cracked or frayed power line. The inappropriate use of power lines and plugs may cause a fire or other dangerous electric shock or burn.

DO NOT clean the oxygen concentrator while plugged in. Unplug the oxygen concentrator before cleaning to prevent electric shock.

DO NOT open the oxygen concentrator's shell and internal box when the unit is operating, to prevent physical or mechanical damage.

The following items must be strictly enforced to prevent serious harm.

Patients should have a backup supplemental oxygen source in case of oxygen concentrator failure during power outage.

DO NOT repair or maintain the oxygen concentrator or the humidifier bottle while in use. The patient can clean and maintain the oxygen concentrator themselves. For the effectiveness of treatment, the oxygen output setting of the oxygen concentrator should be evaluated periodically. Patients with more advanced or severe disease(s) will need additional medical coordination. Please consult a prescriber before use.

Patients who experience adverse reactions should inform the prescriber immediately.

DO NOT change the model of the humidifier bottle at will. Humidifier bottles that meet the specification requirements of supporting products should be used (recommended model: intubated humidifier bottle).

DO NOT place the nasal cannula on or under the bedding, blankets, or cushions when using the oxygen concentrator.

DO NOT sit on the nasal cannula. This may prevent oxygen from passing through the cannula normally, resulting in inability to inhale oxygen.

Turn off the power switch and disconnect the plug when not in use. When the product is turned on without oxygen inhalation, the oxygen will support combustion. The power must be unplugged after use.

Connect the power cord to the nearest power socket. When using this product, pay attention to the power cord. Ensure it is not too long to obstruct walking.

This oxygen concentrator cannot be equipped with non-specified humidifier bottles or dosing accessories, as it may affect the performance of the device.

DO NOT allow infants, children, or other unqualified individuals to touch the oxygen concentrator while using or storing the device, to prevent damage or inappropriate use of the device.

To ensure that the amount of oxygen required for treatment is obtained according to the patient's medical condition, the oxygen concentrator must be:

- Used for one or more settings prescribed to the patient, depending on the specific activity level of the patient.

- For use in a combination of parts and accessories specified in accordance with the requirements of the manufacturer of the oxygen generator and after the settings have been determined for the patient.

DO NOT use petroleum or oil-based washes or oils to avoid the risk of fire. Only water-based washes or oils compatible with oxygen should be used before and during oxygen therapy.

Accessories, connectors, pipes or other parts of the oxygen concentrator must not be lubricated to avoid the risk of fire.

Only spare parts recommended by the manufacturer can be used to ensure proper function and avoid the risk of fire.

Using the oxygen concentrator at altitudes above 2000 meters, temperatures below 41 degrees F (5 degrees C) or above 104 degrees F (40 degrees C), or relative humidity over 80% will affect the oxygen flow, oxygen purity and further affect the quality of treatment.

DO NOT place the nasal cannula or mask on the bed cover or the chair cushion when the oxygen concentrator is running without being used, as these materials can become enriched with oxygen. Oxygen can catch fire and spread fire. The oxygen concentrator should be turned off when not in use.

Seek medical help immediately if the patient feels uncomfortable or has a medical emergency during oxygen therapy.

When the elderly, children, or other patients are unable to express discomfort, additional monitoring measures or distributed alarm systems can be used to communicate discomfort and medical emergencies to responsible caregivers to avoid harm.

Smoking during oxygen therapy is dangerous and may cause in facial burns or death. Smoking is not allowed while in the same room with the oxygen concentrator or any other accessory that contains oxygen. If you plan to smoke, turn off the oxygen concentrator, remove the nasal cannula, and leave the nasal cannula or mask or the place where the oxygen concentrator is placed. If you cannot leave the premises, you must wait 10 minutes after turning off the oxygen concentrator before smoking.

Open flames during oxygen therapy are dangerous and can result in fire or death. No open flame is allowed within 6 feet around the oxygen generator and any oxygen storage place.



## CAUTION:

Read the following caution statements for the safe and effective use of the device.

DO NOT open the shell and internal case of the device for maintenance or repairs. Contact the supplier or manufacturer if there is a quality problem or malfunction.

DO NOT use this product under a strong magnetic field environment.

The oxygen concentrator should be placed in an environment free of pollution and smoke.

The device should be used in a well-ventilated environment. The air intake should be in a place with the least number of contaminants. (Contaminants refer to/include combustion exhaust, other exhaust systems, vents and vacuum exhaust.)

DO NOT connect the AC power adapter to a power strip. Connect the AC power directly to the wall power socket while using this product.

DO NOT use the additional power socket with other electrical appliances at the same time.

DO NOT use oil or grease on the device. If other components must be connected, such connections should be cleaned before installation to ensure that they are clean and free of oil (grease). Keep all parts clean. Prevent any flammable substance such as oil or grease from coming into contact with the device.

The back of the device should not touch the wall and should be operated at a distance of at least 12 inches from the wall. Ensure that the exhaust flows and unobstructed while operating the device. Failure to do so will cause overheating and damage to the device.

DO NOT use other lubricants except those recommended by the manufacturer.

This machine cannot frequently power on and power off. Wait no less than 5 minutes after shutting down to power on the device again. The manufacturer recommends each operation time is no less than 30 minutes to avoid impacting the service life of the compressor.



## NOTICE:

Please note the following additional significant information.

The oxygen purity reaches 90% after booting for 10 min.

The oxygen concentrator should have an auditory prompt 10 minutes after the oxygen concentrator is turned on if there is a power failure.

If the power supply voltage is unstable and exceeds the range of 110V ~ ± 11V, please install a voltage stabilizer before using the device.

If using a humidifier bottle, it needs to be cleaned every day. The intake filter foam needs to be cleaned as needed between device usage. The manufacturer recommends replacing the air intake filter as needed. The air intake filter cannot be reused. If the product is used in a dusty or fume environment, please increase the cleaning or replacement intervals for the above components. Replace the above parts in advance to ensure the effective use of the device.

Do not use untreated tap water directly in the humidifier bottle. The water used in the humidifier bottle can be distilled water or cold boiled water. Change the water in the humidifier bottle every day. Clean the humidifier bottle according to item 2 of the “CLEANING AND MAINTENANCE INSTRUCTIONS.” If you do not use the humidifier bottle, pour out all the water and dry the humidifier bottle.

Choose the humidifier bottle required by the supporting product specifications. Consult a professional physician or the product supplier before changing to a different type of humidifier bottle.

Choose a humidifier bottle that is suitable for this device and connect it to the device as required. Please do not use it in a disassembled state. Refer to the connection instruction diagram of the humidifier bottle.

When using a humidifier bottle only add water to the highest and lowest water level marked on the body.

Service life of main components: The molecular sieve replacement cycle is 15,000 hours of accumulative use of the machine.

Please refer to the “RELATED USE SYMBOL DESCRIPTION” for the symbol instructions on the device, packaging, and manual.



## STATEMENTS:

Oxygen output settings should be performed individually for each patient, depending on the configuration of the device and accessories.

Correct prevention and positioning of the patient interface is the key to therapeutic effectiveness.

When in use, the machine can be turned on to check the running state. There will be an alarm if there is gas leakage or other faults. Please refer to the fault analysis table or contact the supplier to solve the problem.

To check whether the alarm signal is normal, block the oxygen outlet port or unplug the power when the machine is running. The machine will generate an alarm signal. If the device does not alarm, please contact your supplier.

The nasal cannula and humidifier may become contaminated by body fluids or exhalation while the oxygen concentrator is in normal use or in a single fault state.

For basic performance and basic safety checks, please refer to the fault analysis table, or contact the supplier. The recommended detection frequency is 1 time/year.

Do not disassemble the machine without permission. If this occurs, please contact the dealer to ensure the correct connection and repair. Cotton wool, dust may shorten the life of the machine.

## HOMESTYLE Aspen Description

The HOMESTYLE Aspen oxygen concentrator is composed of a compressor, sieve bed, flowmeter, and other parts. The concentrator is designed to deliver up to 5 liters per minute (L/min) of medical grade oxygen.

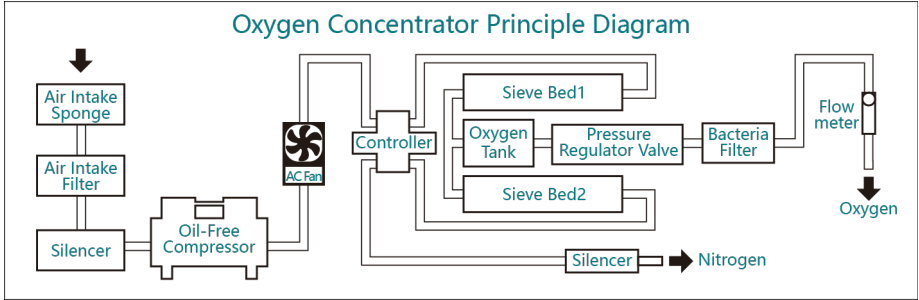

Figure 1

Using ambient air, the molecular sieve pressure swing adsorption process is used to produce oxygen with a concentration range of 90%~96% (V/V) (referred to as 93% oxygen).

## COMPONENTS AND FUNCTIONS

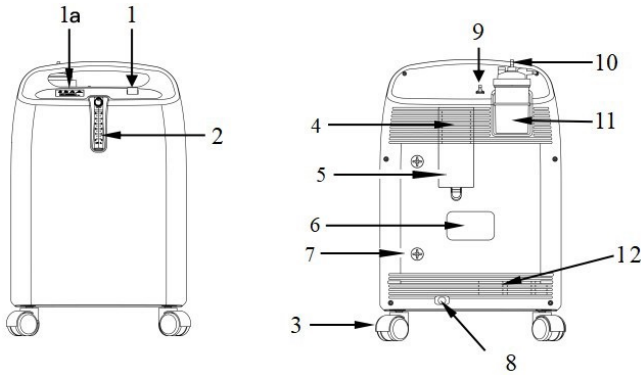

Figure 2

For Component descriptions, please refer to Figure 2\*.

1. Power switch: O = Power off. I = Power on.
2. Flowmeter
  - a. Flow control valve: The switch knob of the oxygen flow meter, adjusts and controls the output oxygen flow.



Figure 3

b. The position of the flow ball in the oxygen flow meter triangle indicates the level of the flow (L/min).



## NOTICE:

Please note the following additional significant information.

Test the oxygen flow meter and make sure the ball is below the max flow 5L/ min mark. Do not allow the ball to exceed the 5L/ min mark. Refer to Figure 3\*.)

The flow rate in the oxygen prescription is very important. Do not increase or decrease the reference flow rate of oxygen provided by your doctor. If the regulator valve of the flow meter is turned clockwise, the flow will decrease, eventually shutting off the flow of oxygen. If turned counterclockwise, the flow will increase.

3. Universal casters (four units): the machine can move easily.
4. Intake filter foam: prevent dirt, dust, and fibers from entering the device (only one piece can be used for the machine).
5. Air intake filter cover: remove the intake filter cover to access the intake filter.
6. Product nameplate/factory number label: product performance label, labeling the product factory number.
7. Winder: (part of back housing) for power cord.
8. AC power cable (with plug).
9. Oxygen outlet: Connect to the humidifier bottle by connecting tube or nasal oxygen tube, with fire break valve together.
10. Humidifier bottle connection tube.
11. Humidifier bottle.
- 12 Heat sink: On the bottom of the machine. Do not block during machine operation.

\* The following parts description refers to the instructions in Figure 4\*

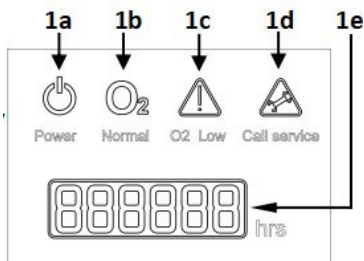

Figure 4

- 1a Green power indicator light—Start operating.
- 1b Green indicator light—Oxygen output normally.

1c Yellow indicator light—Low oxygen purity.

1d Yellow service indicator light please contact for maintenance service.

1e Digital display of hours

## General Instructions

Note: See section Alarm Indicators. The device has the following self-test functions: Low oxygen purity, Cycle fault or oxygen purity  $\leq 72\%$  ( $\pm 3\%$ ) alarm, Low pressure alarm (or the compressor is overheated and will shut down), Cycle fault and low-pressure alarm, High pressure alarm, Cycle fault and high-pressure alarm, Low oxygen flow alarm.

When working normally, the fault monitoring function will monitor the working state of oxygen concentrator. When  $72\% (\pm 3\%) \leq$  oxygen purity  $\leq 82\% (\pm 3\%)$ , the yellow low-oxygen indicator light will be on. If oxygen purity  $\leq 72\% (\pm 3\%)$ , the yellow alarm light will be on with continuous alarm sound.

When the display screen shows Lo-O2, the device will stop within 1 minute. Please turn off the device immediately.

When the device has a low-pressure fault, or the compressor is overheated and shut down, the yellow service indicator light will be on accompanied by a continuous audible alarm, and the display will show Lo-P. The device will stop within 1 minute. Please turn off the device immediately.

When the oxygen concentrator has a cycle fault and low-pressure fault at the same time, the yellow service indicator light will be on accompanied by a continuous audible alarm, and the display will show Lo-PO2. The device will stop within 1 minute. Please turn off the device immediately.

When the oxygen concentrator has a high-pressure fault, the yellow service indicator light will be on accompanied by a continuous prompt sound, and the display screen shows Hi-P. The device will stop within 1 minute. Please turn off the device immediately.

When the oxygen concentrator has a cycle failure and a high-pressure failure at the same time, the yellow service indicator light is on, accompanied by a continuous prompt sound, and the display shows Hi-PO2. The device will stop within 1 minute. Please turn off the device immediately.

When the oxygen flow rate of the oxygen output port is less, and the humidifier bottle or oxygen cannula is blocked, there will be a continuous audible alarm, and the display will display E08.

Note: All the alarm states of the oxygen concentrator of the device are low priority. The alarm system has been set up during manufacturing. The user cannot change the alarm system settings.

## PRECAUTIONS

1. Transport and storage conditions between uses after removal of packaging.
  - 1) Range of Environmental Temperature: -4°F ~ 131°F (-20°C ~ +55°C).
  - 2) Range of Relative Humidity: ≤ 93%; without condensation phenomenon.
  - 3) Range of atmospheric Pressure: 7.25psi~15.37psi (50 kPa~106 kPa).



### NOTICE:

When the storage temperature is lower than 41°F, the device should be placed in the normal working temperature environment for more than four hours before use.

## 2. PRODUCT OPERATION ENVIRONMENT (Including oxygen purity status indicator)

- Environmental Temperature: 41°F~104°F
- Relative Humidity: ≤ 80%.
- Atmospheric Pressure: 12.47psi~15.37psi (86 kPa~106 kPa).
- No corrosive gas or strong magnetic field in the surrounding environment.

## 3. EXPIRY DATE/PRODUCTION DATE

- 1) Expected Service Life: Five years.
- 2) Oxygen concentrator production date: Refer to the specification label.

## OPERATION STEPS

- 1) When the device is in use, the back of the device must be at least 12 inches (30.5 cm) away from the wall. The foam board must be removed. Make sure that no debris is piled up at the bottom to maintain the air circulation and ensure the normal heat dissipation of the machine.
- 2) Connect the humidifier bottle (if needed) and operate according to the following instructions.
  - a. Put cold boiled water or distilled water in the humidifier bottle. The water level must be not more or less than the maximum/minimum water level indicator line of the bottle, and the bottle cap should be tightened fully (Refer to Figure 5\*).

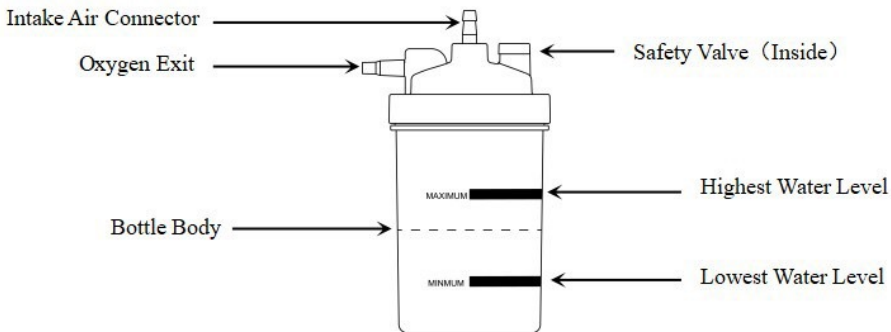

Figure 5

- b. Use the elastic humidifier strap to affix the humidifier bottle on the back shell of the oxygen concentrator, connect one end of the humidifier bottle connecting pipe to the humidifier bottle inlet, and the other end to the oxygen output port of the oxygen concentrator (refer to Figure 6\*).

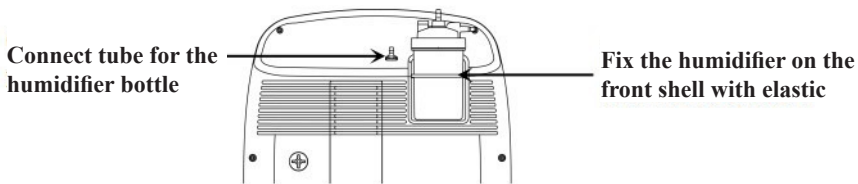

Figure 6

- 3) Remove the AC power cord from the retaining strap, confirm the switch is in the off position. Insert the plug into the power outlet.
- 4) The device is configured with a device to monitor oxygen concentration. Each time the machine is turned on, the power indicator light and normal indicator light on the display will light up. After a few minutes, if the output oxygen purity does not meet the standard requirements, the normal indicator light will be turned off, and the yellow low oxygen indicator light will light up.
- 5) To increase the output flow, turn the knob counterclockwise, to decrease the output flow, turn the knob clockwise. Ensure that the ball is above the desired flow setting in the rotameter.
- 6) Connect the nasal cannula intake air connector to the air outlet of the bottle (if used) or to the concentrator. Place the nasal cannula prongs into the user's nostrils, and the cannula tubing over the user's ears. (It is recommended to use an oxygen inhalation cannula with a medical device registration certificate. Flow range  $\geq 10$  L/min) Refer to Figure 7 for instructions.



Figure 7

- 7) After 10 minutes running, if the alarm is sounded, please check whether the power supply connection is loose, or whether the external power supply has been interrupted.
- 8) Shutdown: Turn off the power switch after use and unplug the AC power cord. Cut off the network power and tidy up the AC power cord.

## Alarm Indicators

Display	Alarm Reference	Alarm Condition
Lo-O2	Cycle Fault	Purity $\leq 72\%$ ( $\pm 3\%$ )
Lo-P	Low Pressure	1. Pressure $< 5.8$ psi or 40kPa 2. The compressor is overheated and shut down
Lo-PO2	Cycle Fault and Low Pressure	Pressure $< 5.8$ psi or 40kPa and purity $\leq 72\%$ ( $\pm 3\%$ )
Hi-P	High Pressure	Pressure $< 36.26$ psi or 250kPa
Hi-PO2	Cycle Fault and High Pressure	Pressure $< 36.26$ psi or 250kPa and purity $< 72\%$
Hi-t	High Temperature	MOS overheated
E08	Humidifier Bottle or Oxygen Pipe Blockage	1. The oxygen outlet port is blocked 2. The flow rate is less than 0.3L/min, and the duration is 15 seconds

## Troubleshooting



### WARNING:

To avoid electric shock, please do not open the shell of the oxygen concentrator. Opening the casing should only be done by professionals authorized by the manufacturer.

The Fault and Repair Comparison Table below will help you analyze and correctly repair the faults of the oxygen concentrator. If the suggested steps do not help, use a spare oxygen concentrator, and notify the supplier of this oxygen concentrator for repair. Please do not attempt any other repairs.

Failures	Probable Cause	Maintenance Methods
The machine does not work. Power light is off when the switch is "on."	The power plug is not properly plugged into the power outlet.	Check whether the power cable is securely connected to the socket.
	No power at the socket.	Check the power cable or change the socket.
The power switch is on, and the oxygen concentrator has been operating for 2 minutes, the service light may be illuminated. Audible alarm may sound.	Air intake filter foam is blocked.	Check the air intake filtering foam. If it is dirty, wash it following "CLEANING AND MAINTENANCE."
	Exhaust port is blocked.	Check the exhaust port of the rear shell to make sure the exhaust port is not blocked.
	The pipe of humidifier bottle is clogged or defective.	Disconnect the humidifier bottle from the device; If flow is restored, then the humidifier bottle needs to be cleaned or replaced.
Both the green normal O <sub>2</sub> light and the yellow low O <sub>2</sub> light are either on or off.	The oxygen concentration sensor is faulty.	Contact your supplier.
There is excess fog or water droplets inside of the oxygen connecting pipe/tubing.	The oxygen from humidifier bottle contains a certain amount of moisture; There will be a certain temperature difference in colder temperatures, which will cause the moisture in the oxygen to condense, so that liquid water drops in the connecting pipe.	Avoid direct exposure of cold air on the oxygen connecting pipe/tubing; If the fog or water droplets in the cannula continue, please contact your Supplier.
	There is no ventilation around the machine, causing the device in a warmer working temperature.	Make sure there are no obstructions within 12 inches of the device.
	The water from humidifier bottle is hotter than the surrounding air.	Make sure to use room temperature water in the humidifier bottle.
Yellow low-O <sub>2</sub> light is on.	The equipment detected a high oxygen flow situation.	Reduce the flow rate to the specified level. Wait for at least 2 minutes. If the situation persists, please turn off the equipment, connect to an alternative oxygen source, and call the home healthcare provider.
	Air intake filter foam is blocked.	Check the air intake filter. If it is dirty, clean it according to "CLEANING AND MAINTENANCE."
	Exhaust port is blocked.	Check the exhaust port, make sure there's nothing restricting the airflow.
Yellow service light is on, accompanied by "beep" sound.	The equipment detected a high oxygen flow situation.	Reduce the flow rate to the specified level. Wait for at least 2 minutes. If the situation persists, please turn off the equipment, connect to an alternative oxygen source, and call the home healthcare provider.
	Air intake filter is blocked.	Check if the air intake filter is blocked. If this is the issue, please clean the debris and check if the air intake filter is dirty. If the issue continues, please replace it as requirement from user manual.
	Exhaust port is blocked.	Check the exhaust port of the rear shell, make sure there's no blockage.
If the machine is still not working properly, please contact the product supplier.		

## Cleaning, Care and Maintenance

Clean the shell of the whole machine: 1-2 times a month. Please wipe the outside of the machine with a clean and soft wet towel dipped in a little detergent when the power is cut off and then dry it with a dry towel.

Clean the air intake filter foam: remove the filter foam inside the air intake filter cover, clean it with detergent, rinse it thoroughly with clean water, remove excess water, dry it naturally in the air, and put it back into the filter cover continue to use. If the filter foam is not completely dry, please do not put it back into the filter cover. Cleaning the intake filter foam is an important part of the maintenance of the oxygen concentrator. It is recommended at least twice a month.



Figure 8



Figure 9

Clean the humidifier bottle (if applicable). You can clean the humidifier bottle separately using detergent and hot water, or use a solution mixed with white vinegar and water at a ratio of 1:3 as a fungicide. Soak the humidifier bottle in this solution for 30 minutes, then dry it.

## Device Repair and Disposal

### REPAIR

Do not attempt to repair the device unless otherwise specified in these instructions for use.

It is recommended that you contact your healthcare provider if your concentrator displays any alarms or if you suspect that it is not functioning properly.

Contact your equipment provider should you have any questions regarding the performance of the device or if the device requires maintenance or repair. You should not attempt to repair the concentrator on your own. Repair should only be performed by a trained service technician.

### DISPOSAL

Follow your local governing ordinances for the disposal and recycling of the device, accessories, and packaging. All electronic devices are a matter of WEEE regulation and must be disposed of according to local governing ordinances in sorted municipal waste or by waste recycling organizations.

### ENVIRONMENT PROTECTION

- Please contact your local supplier or manufacturer when this machine is due for disposal.
- The disposal of waste and residue should be in line with the corresponding national legal provisions.

This Page Intentionally Left Blank

## Technical and Product Specifications

Model No.	SCE1000 Aspen
Power	110V~, 60Hz
Power Consumption	320VA
Flow range when outlet nominal pressure is 0 and 7kpa	0L/min ~ 5L/min
Oxygen purity at 0 outlet nominal pressure (within 10 minutes of initial start-up, the specified purity level is reached)	Flow rate at 1L/min ~ 5L/min, oxygen purity $\geq 90\%$
Maximum flow rate	5L/min
O2 Output Setting	Setting 1: 0.5 L/min ( $\pm 200\text{ml}/\text{min}$ ) Setting 2: 2.0 L/min ( $\pm 10\%$ ) Setting 3: 3.0 L/min ( $\pm 10\%$ ) Setting 4: 4.0 L/min ( $\pm 10\%$ ) Setting 5: 5.0 L/min ( $\pm 10\%$ )
When the maximum flow rate is applied, 7kpa back pressure is applied and the flow rate change scope	$\leq 0.5\text{L}/\text{min}$
When the maximum flow rate is applied, oxygen purity (within 10 minutes of initial start-up, the specified purity level is reached)	$\geq 90\%(V/V)$
Flow regulation range	Continuously adjustable within 0L/min ~ 5L/min
Net weight	32 lbs (14.5 kg)
Noise	$\leq 40\text{ dB(A)}$
Dimension	380mm(L) × 228mm(W) × 592mm(H)
Outlet Pressure	40kPa~60kPa. The maximum shall not exceed 60kPa.
Yellow low-oxygen indicator light	When $72\% (\pm 3\%) \leq \text{purity} \leq 82\% (\pm 3\%)$ , the yellow indicator light will be on, contact the supplier. The user can continue to use and ensure that there is back up oxygen.
Yellow service indicator light	When oxygen purity $\leq 72\% (\pm 3\%)$ , yellow indicator light will be on with a continuous beep, and display screen show Lo-O2 error code. The machine will be stopped within one minute. Please turn off device at once and use the backup oxygen; contact the supplier.

- Compressor safety valve release pressure: 250kPa $\pm$ 50 kPa.
- The Oxygen Concentration Status Indicator (OCSI) indicates when the oxygen concentration in the finished gas is abnormal, and the tolerance of the oxygen concentration is  $\pm 3\%$ .
- Altitude between 0-2000 meters, Purity  $\geq 90\%$ , when Altitude between 2001-4000 meters, Purity  $\leq 90\%$ .
- Oxygen outlet temperature:  $\leq 46^\circ\text{C}$ .

**SUPPLEMENTARY INFORMATION**

Classification of protection against electric shock: Class II.

Classified according to the degree of protection against electric shock: Class BF. Classified according to the degree of protection of the liquid into the machine: IP21.

Classified according to the degree of safety when used in the case of flammable anesthetic gas mixed with air or flammable anesthetic gas mixed with oxygen or nitrous oxide: non-AP/APG type.

Classified by operating mode: continuous operation. No signal output and signal input part. Working voltage: 110V~, 60Hz.

Duty system: This device is a continuous operation system.

Oxygen concentrators without applied parts are protected against the effects of defibrillation discharge. Oxygen concentrators are non-permanent installations.

**Basic Performance**

1. After the oxygen concentrator has been turned on for 10 minutes, the oxygen purity should reach a level of  $\geq 90\%$  under the set flow condition.
2. Alarm function of corresponding state (low oxygen, power failure, cycle failure, low pressure fault, high pressure fault, high temperature fault, blocking fault, sound prompt and indicator light prompt).

Serial number	Name	Cable length (m)	Weather shield	Remark
1	power cable	2	No	/

**ELECTRICITY SCHEMATIC DIAGRAM**



**NOTICE:**

If there is a need for maintenance, the circuit diagram and necessary information for maintenance can be provided. Contact the manufacturer if you have any questions about circuit servicing.

Fuse type: T5AL250V, Size: 8.35mm x 4.3mm x 7.7 mm.

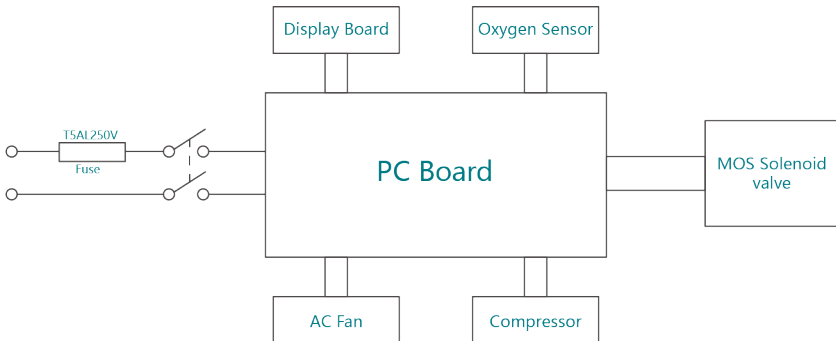

Figure 10

**ELECTRONIC COMPONENTS**

No.	Description	Qty	Unit
1	PC Board	1	Piece
2	Display Board	1	Piece
3	Oxygen sensor	1	Piece
4	MOS Solenoid Valve	1	Piece
5	Compressor	1	Piece
6	AC Fan	1	Piece
7	Power Switch	1	Piece

**ELECTROMAGNETIC COMPATIBILITY****Attention**

- Oxygen concentrators comply with IEC 60601-1-2:2014 standard electromagnetic compatibility related requirements.
- Users should install and use according to the Electromagnetic Compatibility Information provided in the accompanying documentation.
- Performance of oxygen concentrator may be affected by portable and mobile RF communication devices. Avoid strong electromagnetic interference during use, such as near cell phones, microwave ovens, etc.
- The guidelines and manufacturer's declaration are included in this document.

**WARNING:**

Should not be used close to or stacked with other equipment. If it must be used close or stacked, it should be observed to verify that it works properly in the configuration in which it is used.

Apart from cables offered by the manufacturer of the oxygen concentrator as spare parts for internal components, the use of accessories and cables other than those specified may result in increased emission or reduced immunity of the oxygen generator.

For accessories, transducers or cables that are not specified, use with the oxygen concentrator may result in reduced emission or immunity of the oxygen concentrator.

### Guidelines and Manufacturer's Statement — Electromagnetic Emission

Oxygen concentrators are expected to be used in the following specified electromagnetic environment and the purchaser or user of oxygen concentrators shall ensure that it is used in such electromagnetic environment.

Launch Test	Conformity	Electromagnetic Environment - Guide
RF emissions CISPR 11	Group 1	Oxygen concentrators use RF energy only for their internal functions. Therefore, its RF emission is very low and the possibility of interference to nearby electronic devices is minimal.
RF emissions CISPR 11	Class B	Oxygen concentrators are suitable for use in all facilities, including domestic facilities and direct connection to the domestic residential public low voltage supply network.
Harmonic emissions IEC 61000-3-2	Class A	
Voltage fluctuation/ flicker emission	Conformity	

### Guidance and Manufacturer's Statement —Electromagnetic Immunity

Oxygen concentrators are expected to be used in the following specified electromagnetic environment and the purchaser or user of oxygen concentrators shall ensure that it is used in such electromagnetic environment.

Immunity test	IEC 60601 test electrical level	Conformity Leveling	Electromagnetic Environment-Guide
Electrostatic discharge (ESD) IEC 61000-4-2	±8 kV contact ±2 kV, ±4 kV, ±8 kV, ±15 kV air	±8 kV contact ±2 kV, ±4 kV, ±8 kV, ±15 kV air	The floor should be wood, concrete or tile, and if the floor is covered with synthetic material, the relative humidity should be at least 30%.
Electric fast transient pulse train IEC 61000-4-4	±2kV For power cords ±1kV For input/output lines	±2kV For power cords	Network power should have qualities typical of use in a commercial or hospital environment
Surge IEC 61000-4-5	±1 kV differential mode voltage ±2 kV common mode voltage	±1 kV line to line	Net power should have qualities typical of use in a commercial or hospital environment.
Voltage transients, short interruptions and voltage variations on the power input line IEC 61000-4-11	<5 % UT, Lasting 0.5 cycles (On UT, >95% of temporary drop) 40 % UT for 5 cycles (On UT, 60% of the temporary drop) 70 % UT for 25 cycles (On UT, a 30% temporary drop)<5% UT, Lasting 5s (On UT, >95% of temporary drop)	<5 % UT, Lasting 0.5 cycles (On UT, >95% of temporary drop) 40 % UT for 5 cycles (On UT, 60% of the temporary drop) 70 % UT for 25 cycles (On UT, a 30% temporary drop)<5% UT, Lasting 5s (On UT, >95% of temporary drop)	The network power supply should be of a quality typical of use in a commercial or hospital environment. If users of oxygen concentrators need continuous operation during power interruptions, an uninterruptible power supply or battery power is recommended.
Industrial frequency magnetic field (50/60Hz) IEC 61000-4-8	30A/m	30A/m	The I.F. magnetic field should have the I.F. and magnetic field level characteristics typical of a site in a typical commercial or hospital environment.

## Guidance and Manufacturer's Statement —Electromagnetic Immunity

Oxygen concentrators are intended use in the electromagnetic environment specified below and the purchaser or user of oxygen concentrators shall ensure that it is used in such electromagnetic environment.

Immunity test	IEC 60601 test electrical level	Conformity Leveling	Electromagnetic Environment-Guide
Radio Frequency Conduction IEC 61000-4-6	3Vrms 150kHz~80MHz 6 Vrms in ISM bands	3Vrms 150kHz~80MHz 6 Vrms in ISM bands	<p>Portable and mobile RF communication equipment should not be used closer to any part of the Oxygen Concentrator, including cables, than the recommended isolation distance. This distance is calculated by the formula corresponding to the frequency of the transmitter.</p> <p>Recommended isolation distance  <math>d = 3.5\sqrt{P}</math></p> <p><math>d = 1.2\sqrt{P} = 80 \text{ MHz to } 800 \text{ MHz}</math></p> <p><math>d = 2.3\sqrt{P} = 800 \text{ MHz to } 2700 \text{ MHz}</math></p> <p>where <math>P</math> is the maximum output power rating of the transmitter in watts (W) according to the transmitter manufacturer and <math>d</math> is the recommended separation distance in meters (m).</p> <p>Field strengths from fixed RF transmitters, as determined by an electromagnetic site survey,<sup>a</sup> should be less than the compliance level in each frequency range.<sup>b</sup></p> <p>Interference may occur in the vicinity of equipment marked with the following symbol:</p> 
Radio Frequency	3 Vrms 80 MHz ~ 2.7 GHz	3 Vrms 80 MHz ~ 2.7 GHz	
Radiation IEC 61000-4-3	385 MHz-5785 MHz Test specifications for ENCLOSURE PORT IMMUNITY To RF wireless Communication equipment (Refer to table 9 of IEC 60601-1-2:2014)	385 MHz-5785 MHz Test specifications for ENCLOSURE PORT IMMUNITY To RF wireless Communication equipment (Refer to table 9 of IEC 60601-1-2:2014)	

NOTE 1: At 80 MHz and 800 MHz, the higher frequency range applies.

NOTE 2: These guidelines may not be appropriate in all cases. Electromagnetic propagation is influenced by absorption and reflection from buildings, objects and the human body.

<sup>a</sup> Strong fixed transmitter field, such as: base stations for wireless (cellular/cordless) telephony and terrestrial mobile radio, amateur radio, AM (Amplitude Modulation) and FM (Frequency Modulation) radio broadcasts, and television broadcasts, etc. None of its field strength can be accurately predicted in theory. In order to evaluate the electromagnetic environment of fixed RF transmitter, the survey of electromagnetic field house should be considered. If the measured field strength of the oxygen concentrator at the site is higher than the above applicable RF compliance level, the oxygen concentrator should be observed to verify that it can operate properly. If abnormal performance is observed, it may be necessary to take additional measures, such as reorienting or repositioning the oxygen concentrators.

<sup>b</sup> In the entire frequency range from 150kHz to 80MHz, the field strength should be less than 3V/m.

**Recommended separation distances between portable and mobile RF communications equipment and the Automatic Wrist Blood Pressure Monitor**

The OXYGEN CONCENTRATOR is intended for use in an electromagnetic environment in which radiated RF disturbances are controlled. The customer or the user of the OXYGEN CONCENTRATOR can help prevent electromagnetic interference by maintaining a minimum distance between portable and mobile RF communications equipment (transmitters) and the OXYGEN CONCENTRATOR as recommended below, according to the maximum output power of the communications equipment.

Rated maximum output of transmitter (W)	Separation distance according to frequency of transmitter (m)		
	m		
	150 kHz to 80 MHz $d = 1.2\sqrt{P}$	80 MHz to 800 MHz $d = 1.2\sqrt{P}$	800 MHz to 2.7 GHz $d = 2.3\sqrt{P}$
0.01	0.12	0.12	0.23
0.1	0.38	0.38	0.73
11	1.2	1.2	2.3
10	3.8	3.8	7.3
100	12	12	23

For transmitters rated at a maximum output power not listed above, the recommended separation distance d in meters (m) can be estimated using the equation applicable to the frequency of the transmitter, where P is the maximum output power rating of the transmitter in watts (W) according to the transmitter manufacturer.

NOTE 1 At 80 MHz and 800 MHz, the separation distance for the higher frequency range applies.

NOTE 2 These guidelines may not apply in all situations. Electromagnetic propagation is affected by absorption and reflection from structures, objects and people.

## Test specifications for ENCLOSURE PORT IMMUNITY to RF wireless communications equipment

Test frequency (MHz)	Band <sup>a)</sup> (MHz)	Service <sup>a)</sup>	Modulation <sup>b)</sup>	Maximum power (W)	Distance (m)	IMMUNITY TEST LEVEL (V/m)
385	380-390	TETRA 400	Pulse modulation <sup>b)</sup> 18Hz	1.8	0.3	27
			FM <sup>c)</sup>			
		GMRS 460,				
450	430-470		±5 kHz deviation	2	0.3	28
		FRS 460				
			1 kHz sine			
710	704-787	LTE Band 13,17	Pulse modulation <sup>b)</sup> 217Hz	0.2	0.3	9
745						
780						
810						
870		GSM 800/900,				
930		TETRA 800,	Pulse modulation <sup>b)</sup>	2	0.3	28
	800-960	iDEN 820,	18Hz			
		CDMA 850,				
		LTE Band 5				
1 720		GSM 1800;				
1 845		CDMA 1900;				
		GSM 1900;	Pulse modulation <sup>b)</sup>	2	0.3	9
	1 700-1 900	DECT;				
1 970		LTE Band 1,	217Hz			
		3, 4, 25;				
		UMTS				
		Bluetooth,				
		WLAN,	Pulse modulation <sup>b)</sup>	2	0.3	28
2 450	2 400-2 570	802.11 b/g/n,				
		RFID 2450,	217Hz			
		LTE Band 7				
5 240	5 100-5 800	WLAN 802.11a/n	Pulse modulation <sup>b)</sup> 217Hz	0.2	0.3	9
5 500						
5 785						

NOTE: If necessary to achieve the IMMUNITY TEST LEVEL, the distance between the transmitting antenna and the ME EQUIPMENT or ME SYSTEM may be reduced to 1 m. The 1 m test distance is permitted by IEC 61000-4-3.

a) For some services, only the uplink frequencies are included.

b) The carrier shall be modulated using a 50% pulse duty cycle square wave signal.

c) As an alternative to FM modulation, 50% pulse modulation at 18 Hz may be used because while it does not represent actual modulation, it would be worst case.

## Limited Warranty Statement

### Limited Warranty Statement for CAIRE HOMESTYLE™ (“Equipment”)

CAIRE warrants to the original Purchaser that all newly manufactured Equipment shall be free from defects in materials and workmanship for a period of three (3) years from the date of shipment to Purchaser, unless Purchaser has purchased any warranty extensions offered by CAIRE, in which case, the warranty shall be extended for such additional duration. All repaired or refurbished Equipment has the warranty period of ninety (90) days from the date the Equipment is returned to the Purchaser, or the unexpired new product warranty period, whichever is longer. This warranty excludes consumables such as nasal cannula and humidifier bottles.

During the applicable warranty period, subject to the terms set forth below, CAIRE will repair or replace any defective parts within a reasonable period of time and free of charge. The original Purchaser shall refer only to the party issuing the purchase order to CAIRE for the Equipment, whether or not the Purchaser is the end user of the Equipment. The warranties contained herein are not transferable. Any claim for breach of warranty must be made in writing within sixty (60) days of discovery of a purported defect and within the applicable warranty period.

CAIRE will not be responsible for any alleged breach of warranty which CAIRE determines after inspection to have arisen from a cause not covered by this warranty, which are defects or damages caused by, resulting from or demonstrating: (1) normal wear and tear, including, cosmetic defects such as discoloration or scratches; (2) improper operation, maintenance, installation, storage, abuse, accident or neglect including lack of user and/or provider required preventative maintenance and/or calibration; (3) external impact such as ingress of liquids, water, rain, extreme humidity, sand, dirt or the like; (4) natural disasters such as earthquake, fire, flood, or other acts of God; (5) any modifications or repairs made by persons other than CAIRE or CAIRE authorized persons or using equipment or parts other than those authorized by CAIRE in writing; and (6) any change or removal of serial numbers or lot (date) code, any mismatching board serial numbers or revision combinations, broken seals or evidence that shows tampering, or use of non-conforming or non-CAIRE parts or components. If, upon inspection, the Equipment is determined to be without a

covered defect, Purchaser will be responsible for CAIRE’s time and material costs related to the inspection and all freight charges.

If Purchaser believes the Equipment does not comply with this warranty, Purchaser shall contact CAIRE Customer Service as set forth below:

Americas: [customerservice.usa@caireinc.com](mailto:customerservice.usa@caireinc.com)  
 EMEA: [customerservice.europe@caireinc.com](mailto:customerservice.europe@caireinc.com)

Purchaser shall return the Equipment freight prepaid, properly packaged in a CAIRE approved shipping container and properly identified by a Return Materials Authorization (“RMA”) number issued by CAIRE. Equipment returned without an RMA number may be refused and returned at Purchaser’s expense. At its sole discretion, CAIRE may use functionally equivalent refurbished, reconditioned, or pre-owned parts, accessories, and/or components, to repair all warranted Equipment. In addition, CAIRE may require that Purchaser return the defective Equipment as a condition to receiving the replacement Equipment.

The remedies set forth above are the Purchaser’s sole and exclusive remedy in case of breach of the warranties set forth herein. CAIRE SHALL NOT BE LIABLE FOR, AND PURCHASER SHALL INDEMNIFY, DEFEND AND HOLD CAIRE HARMLESS FROM ANY CLAIMS ARISING OUT OF THE USE, SALE, OR LEASE OF THE EQUIPMENT, CAIRE’S COMPLIANCE WITH PURCHASER’S DESIGNS, SPECIFICATIONS OR INSTRUCTIONS, OR MODIFICATION OF ANY EQUIPMENT BY PARTIES OTHER THAN CAIRE, PURCHASER’S FAILURE TO COMPLY WITH THIS WARRANTY, OR USE OF THE EQUIPMENT IN COMBINATION WITH OTHER EQUIPMENT. PURCHASER’S RECOVERY FROM CAIRE FOR ANY CLAIM SHALL NOT EXCEED PURCHASER’S PURCHASE PRICE FOR THE EQUIPMENT GIVING RISE TO SUCH CLAIM, AND PURCHASER SHALL NOT IN ANY EVENT BE ENTITLED TO, AND PURCHASER SHALL INDEMNIFY, DEFEND AND HOLD CAIRE HARMLESS FROM, ANY CLAIMS FOR, INDIRECT, SPECIAL, PUNITIVE, INCIDENTAL OR CONSEQUENTIAL DAMAGES OF ANY NATURE. THE FOREGOING SHALL APPLY IRRESPECTIVE OF THE NATURE OF THE CLAIM, WHETHER BASED ON CONTRACT, WARRANTY, TORT, NEGLIGENCE, STRICT LIABILITY OR OTHERWISE. THE REMEDIES AND WARRANTIES STATED

IN THIS WARRANTY ARE EXCLUSIVE AND IN LIEU OF ALL OTHER REMEDIES AND WARRANTIES GRANTED UNDER APPLICABLE LAW, INCLUDING, WITHOUT LIMITATION, WARRANTIES OF QUALITY, PERFORMANCE AND DESIGNS, AND ALL OTHER WARRANTIES, INCLUDING ANY IMPLIED WARRANTIES OF MERCHANTABILITY AND FITNESS FOR A PARTICULAR PURPOSE OR ARISING FROM COURSE OF DEALING OR USAGE OF TRADE, ALL OF WHICH ARE HEREBY EXPRESSLY DISCLAIMED BY CAIRE.

## Trademarks and Disclaimer

CAIRE, CAIRE Inc. and HOMESTYLE™ are registered or unregistered trademarks of CAIRE Inc. Please visit our website for a full listing of trademarks: [www.caireinc.com/corporate/trademarks](http://www.caireinc.com/corporate/trademarks).

© Copyright 2025 CAIRE Inc. All Rights Reserved. No part of this document may be reproduced in any manner, in whole or in part (except for brief excerpts in reviews and scientific papers), without the prior written consent of CAIRE Inc. CAIRE Inc. reserves the right to change the content of this document, discontinue its products, or change the prices, materials, descriptions, specifications and/or processes at any time without prior notice.

Any use of this device outside its approved indications for use is considered off-label and is the sole responsibility of the user. This device may not be approved in all jurisdictions. Users must comply with local regulations.

## Contact Information

CAIRE Inc. may be contacted via one of the methods indicated below:

Corporate contact details:

Phone +1-770-721-7700

Fax: +1-770-721-7701

[www.caireinc.com](http://www.caireinc.com)

Americas: [customerservice.usa@caireinc.com](mailto:customerservice.usa@caireinc.com)

EMEA: [customerservice.europe@caireinc.com](mailto:customerservice.europe@caireinc.com)

## Questions about your HOMESTYLE Aspen?

Please contact CAIRE at:

[customerservice@caireinc.com](mailto:customerservice@caireinc.com)

800-482-2473

2200 Airport Industrial Drive, Suite 500, Ball Ground, GA 30107

## Questions about your condition or prescription?

Please contact your prescribing physician or healthcare provider.

Healthcare Professionals: To report an adverse event experienced while using a CAIRE device, please contact CAIRE customer service at [customerservice@caireinc.com](mailto:customerservice@caireinc.com) or report directly to the United States Food and Drug Administration (FDA) at MedWatch: <https://www.fda.gov/safety/medwatch-fda-safety-information-and-adverse-event-reporting-program> or 1-800-FDA-1088.

Consumers: To report an adverse event experienced while using your HOMESTYLE Aspen, please contact CAIRE customer service at [customerservice@caireinc.com](mailto:customerservice@caireinc.com) or report directly to the United States Food and Drug Administration (FDA) at MedWatch: <https://www.fda.gov/safety/medwatch-fda-safety-information-and-adverse-event-reporting-program> or 1-800-FDA-1088.

In an emergency, please dial 911.

Non-U.S. residents: Countries outside the United States may have specific procedures in place to address reports of adverse events. Please contact your healthcare provider or your local health authority for more information.

This Page Intentionally Left Blank

This Page Intentionally Left Blank

This Page Intentionally Left Blank



[www.caireinc.com](http://www.caireinc.com)



Manufactured for CAIRE Inc.  
2200 Airport Industrial Dr., Ste. 500  
Ball Ground, GA 30107 U.S.A.

© Copyright 2025 CAIRE Inc. All Rights Reserved. CAIRE Inc. reserves the right to discontinue its products, or change the prices, materials, equipment, quality, descriptions, specifications and/or processes to its products at any time without prior notice and with no further obligation or consequence. All rights not expressly stated herein are reserved by us, as applicable.

3 December 2025 MN273 D